

Reg No.: _____

Name: _____

APJ ABDUL KALAM TECHNOLOGICAL UNIVERSITY
FIFTH SEMESTER B.TECH DEGREE EXAMINATION(S), MAY 2019

Course Code: CS301

Course Name: THEORY OF COMPUTATION

Max. Marks: 100

Duration: 3 Hours

PART A

Answer all questions, each carries 3 marks.

Marks

- | | | |
|---|---|-----|
| 1 | What is a Finite state automata? | (3) |
| 2 | Construct DFA for the language 101^* | (3) |
| 3 | Give the regular expression for the language: strings of 'a' and 'b' containing at least two 'b'. | (3) |
| 4 | What is a two-way finite automata? | (3) |

PART B

Answer any two full questions, each carries 9 marks.

- 5 a) Find the regular expression corresponding to the language of the given DFA. (4.5)

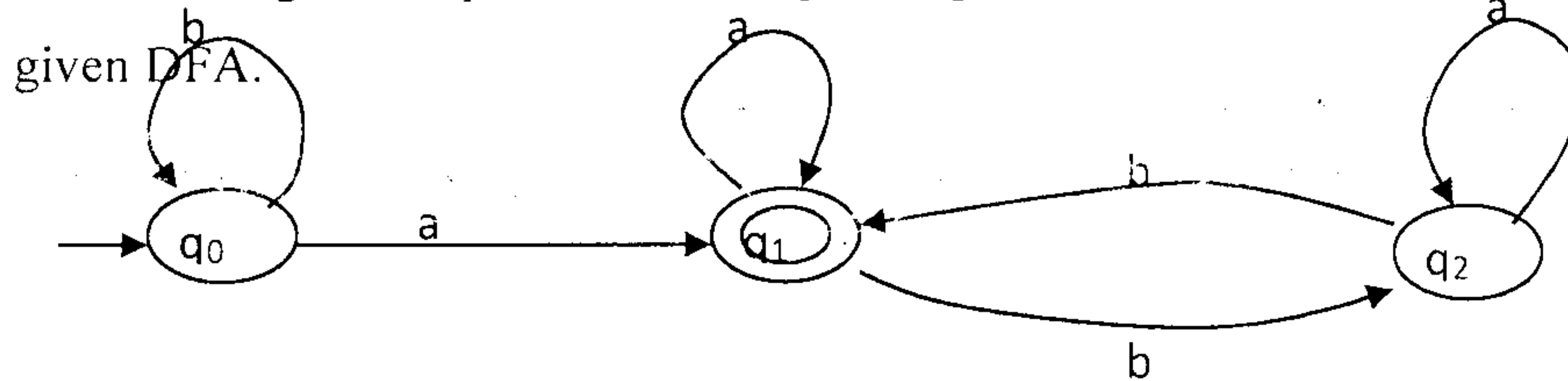

- b) Prove the equivalence of NFA and ϵ -NFA. (4.5)

- 6 a) Convert the ϵ -NFA to NFA. (4.5)

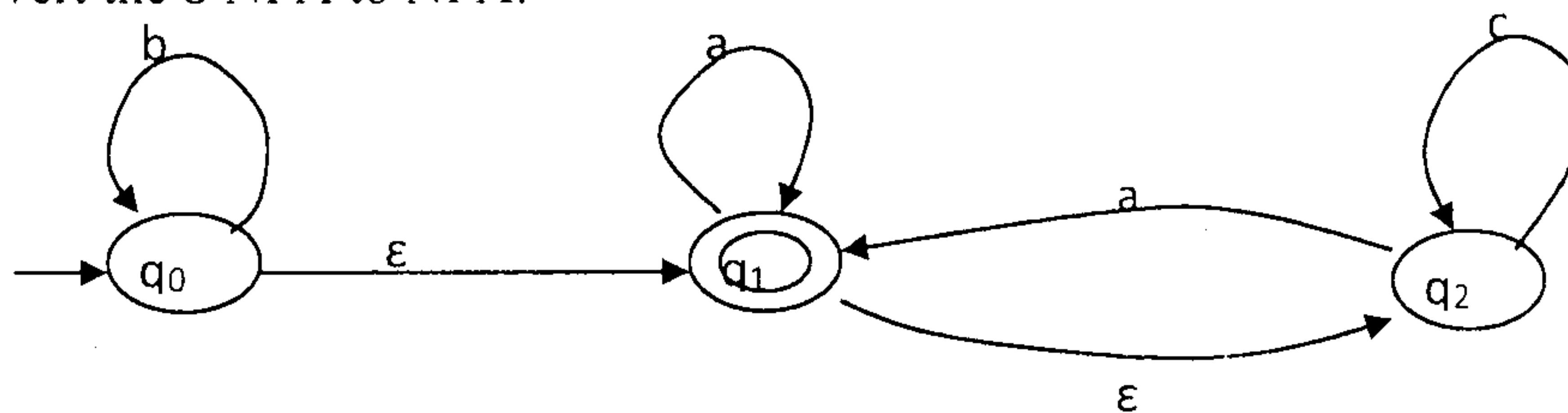

- b) Prove the equivalence of regular expression and finite state automata (4.5)

- 7 a) Compare the transition functions of DFA, NFA and ϵ -NFA. (4.5)

- b) Minimize the states of the DFA given below (4.5)

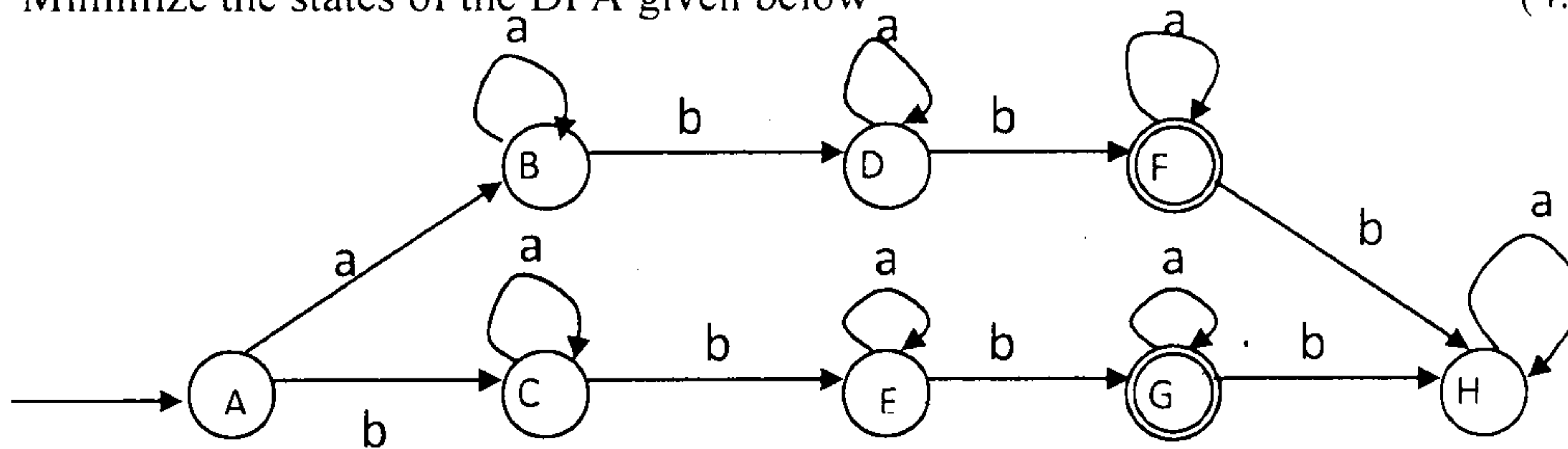

PART C

Answer all questions, each carries 3 marks.

- 8 Give the CFG for the language ww^R where w is string of zeroes and ones. (3)
- 9 What is a derivation tree? Give an example. (3)
- 10 Compare DPDA and NPDA. (3)
- 11 Explain any two closure properties of CFL. (3)

PART D

Answer any two full questions, each carries 9 marks.

- 12 a) Prove that the language 1^n0^n is non-regular where $n > 0$. (4.5)
- b) Construct PDA for the language wcw^R where w is string of zeroes and ones. (4.5)
- 13 a) Prove the equivalence of PDA accepting by empty stack and final states (4.5)
- b) Convert the grammar $\{S \rightarrow ABaC|ABa, A \rightarrow Aa|a, B \rightarrow BaB|b, C \rightarrow CC\}$ to Chomsky normal form. (4.5)
- 14 a) Convert to Greibach Normal form. $\{S \rightarrow AB, A \rightarrow SA|AA|a, B \rightarrow SB|b\}$ (4.5)
- b) Prove the equivalence of CFG and PDA. (4.5)

PART E

Answer any four full questions, each carries 10 marks.

- 15 a) Prove that $a^n b^n c^n$ is non-context free language where $n > 0$. (5)
- b) What is a Universal Turing Machine? (5)
- 16 a) What is Pumping lemma for CFL? (5)
- b) What is Halting problem? (5)
- 17 a) What is Linear Bounded Automata? (5)
- b) What is Chomsky hierarchy? Give example for each type. (5)
- 18 a) Give the context sensitive grammar for the language $a^n b^n c^n$ where (5)